



Co-funded by the
Erasmus+ Programme
of the European Union

Collection of materials for technical tasks solved within the project

FIT FOR CAREER

between 1 September 2019 and 30 June 2022 by



**Vyšší odborná škola, Obchodní akademie a Střední odborné
učiliště technické Chotěboř, the Czech Republic**



Profesionalna gimnazia „Ivan Hadzhienov“, Kazanlak, Bulgaria



Istituto Superiore „Enzo Ferrari“, Barcellona P.G., Italy



Colegio Salesiano Santísima Trinidad, Sevilla, Spain



The European Union is not responsible for the quality and the content of the material.

3D modeling in English

SolidWorks basics

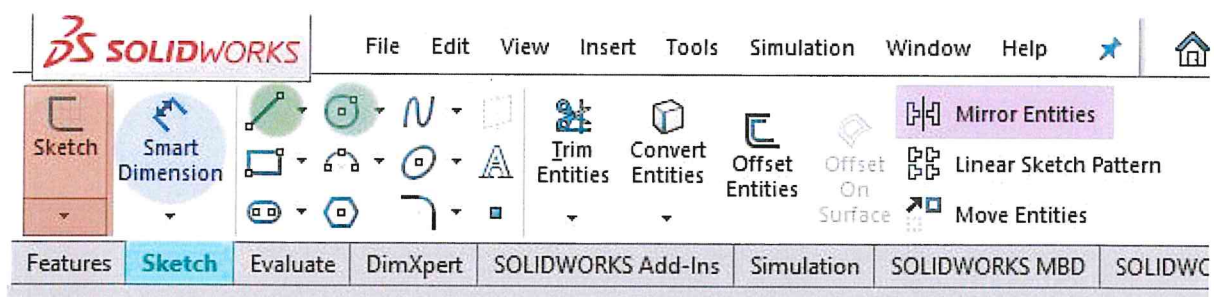
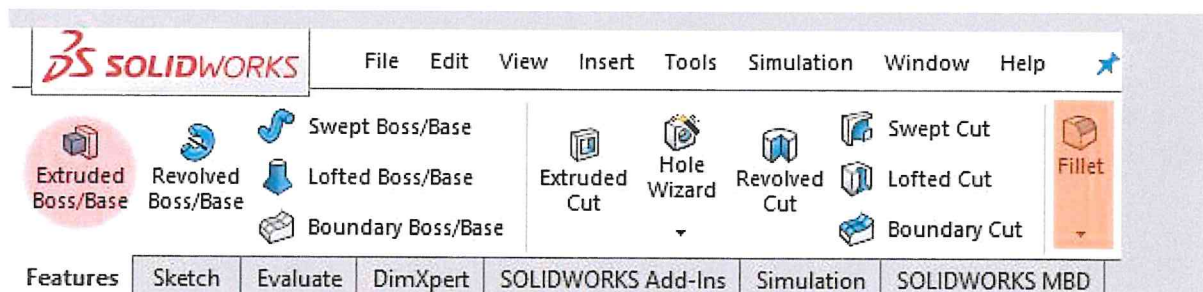

1. Select new part.
2. Choose **Sketch**, click **Sketch**, select Front Plane.

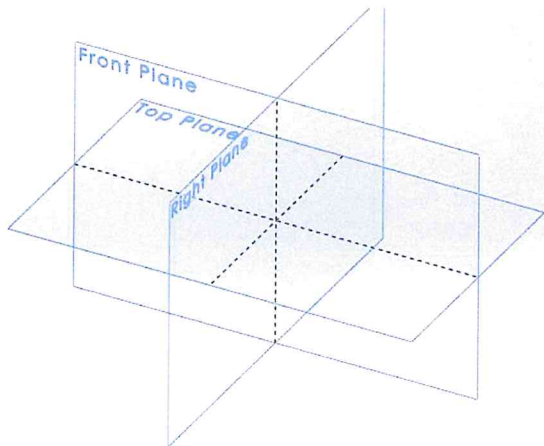

3. Draw a rectangle as a base.

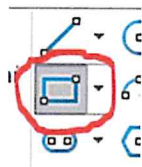

4. Select **Smart Dimension** and enter appropriate values (170x18).

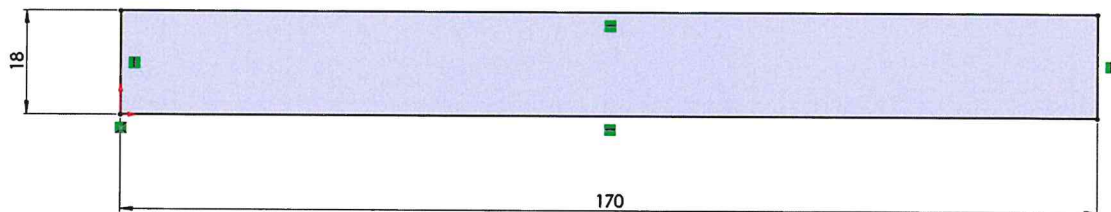

5. Select the **Line tool** - Centerline, mouse over the top line, and draw a centerline.

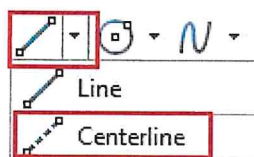

6. Select the **Line tool** - Line. Sketch the first half of the outline.

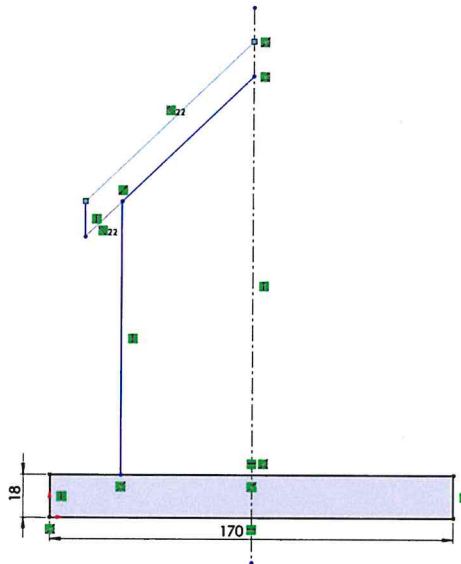

7. Next, choose **Mirror Entities**, select the outline, click on the center line and confirm.

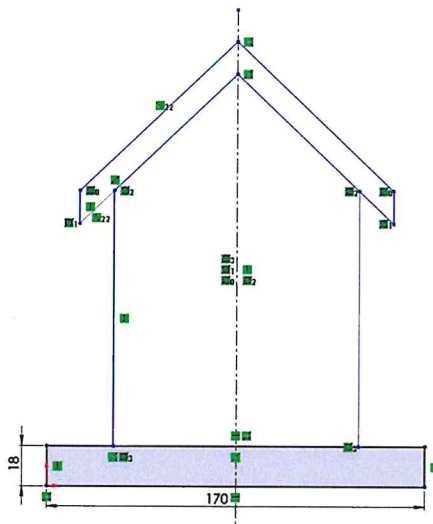

7. Select the **Circle Tool** – Circle and sketch the outline of holes.

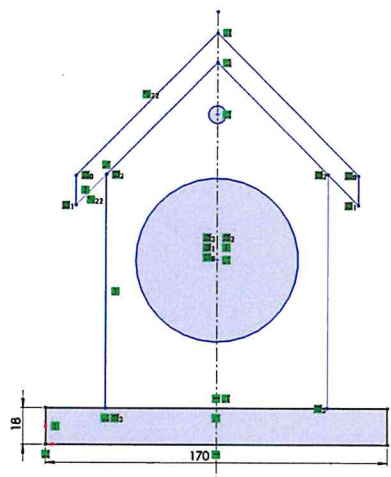
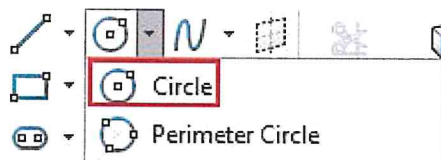

8. Use **Smart Dimensions** to set correct values.

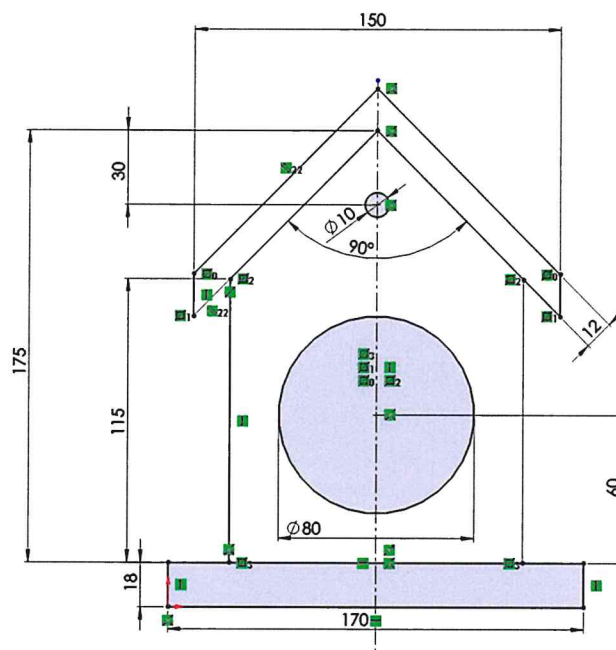

9. Next, we are going to convert the model to 3D graphics.
- Go to features and click on **Extruded Boss/Base**.
 - In the Direction dropdown menu select **Mid Plane**, set values according to documentation and then confirm.
 - In the left panel (Feature Manager) select **Boss/Extrude**, then click on **Sketch1**.
 - Select **Extruded Boss/Base** in the upper right corner and select next part.
 - Repeat until done.

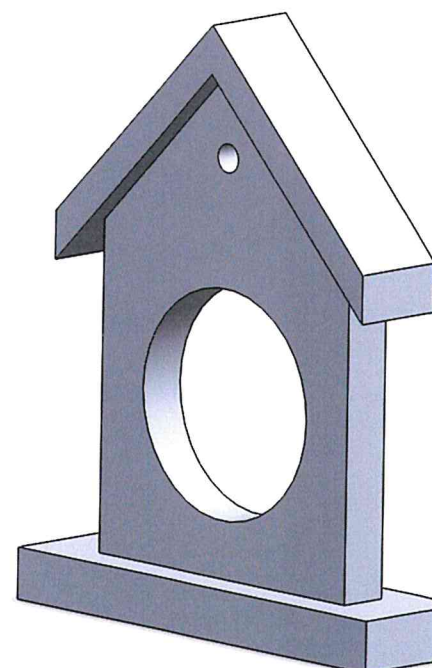
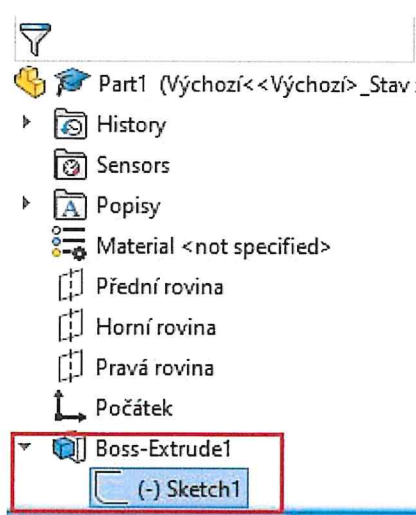
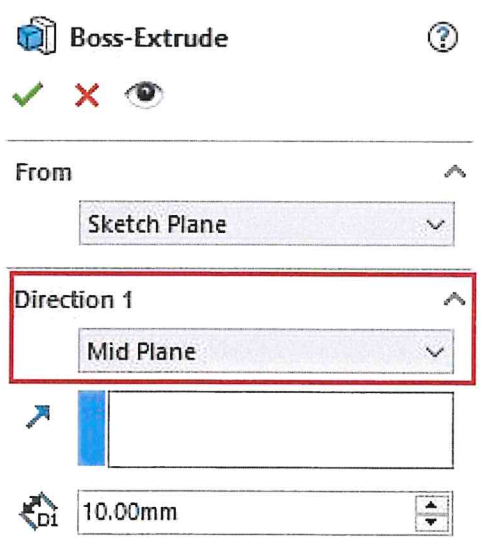

11. Select the **Fillet tool** – Chamfer (2,5 x 45) and use it on the edges of the lower part.

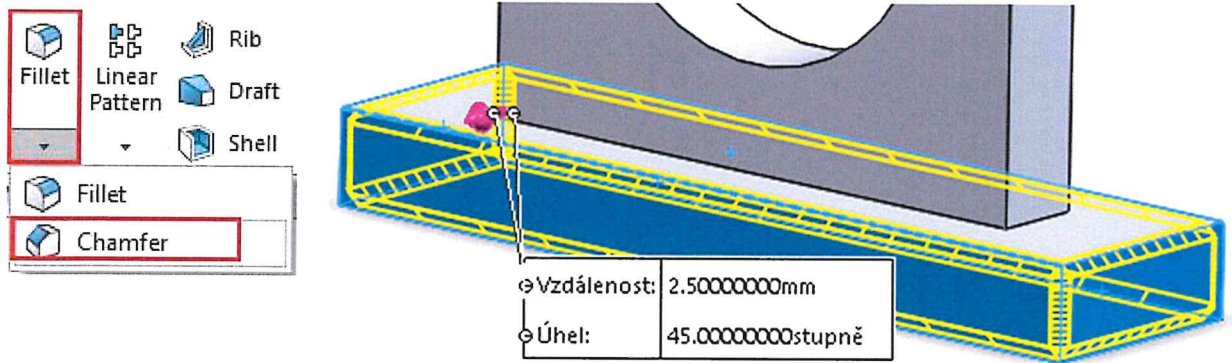

12. Set view to side view (CTRL-3).

- Use the Circle Tool to draw a circle and set its dimension.
- Go to Features and select Extruded Cut.
- In the panel choose Direction 1: Through All, confirm.

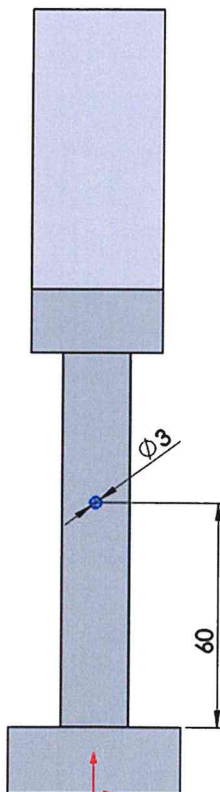

a)

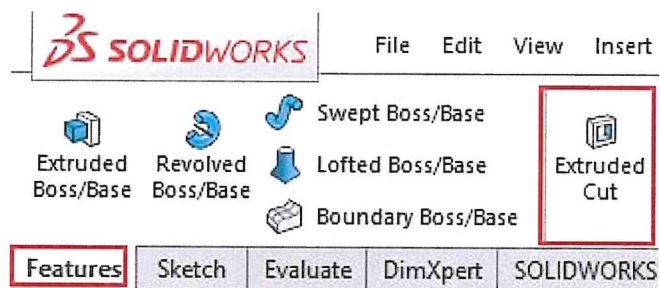

b)

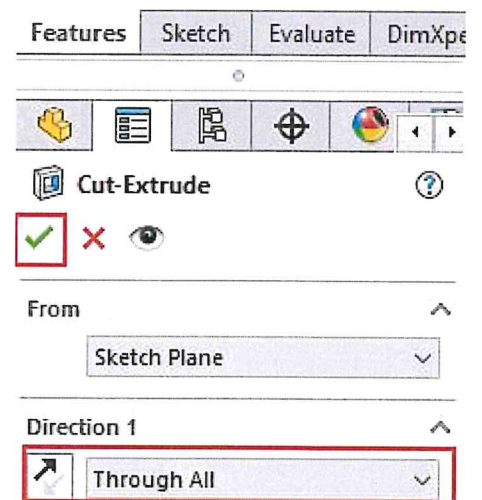

c)

Some additional information:

CTRL + Numerics (1, 2, 3...) can be used to rotate the sketch.

- You can also press the mouse wheel to do the same.

All values are measured in mm.

If you scroll too far, you can press F to return to the default position.

Do not close the program without saving in advance.

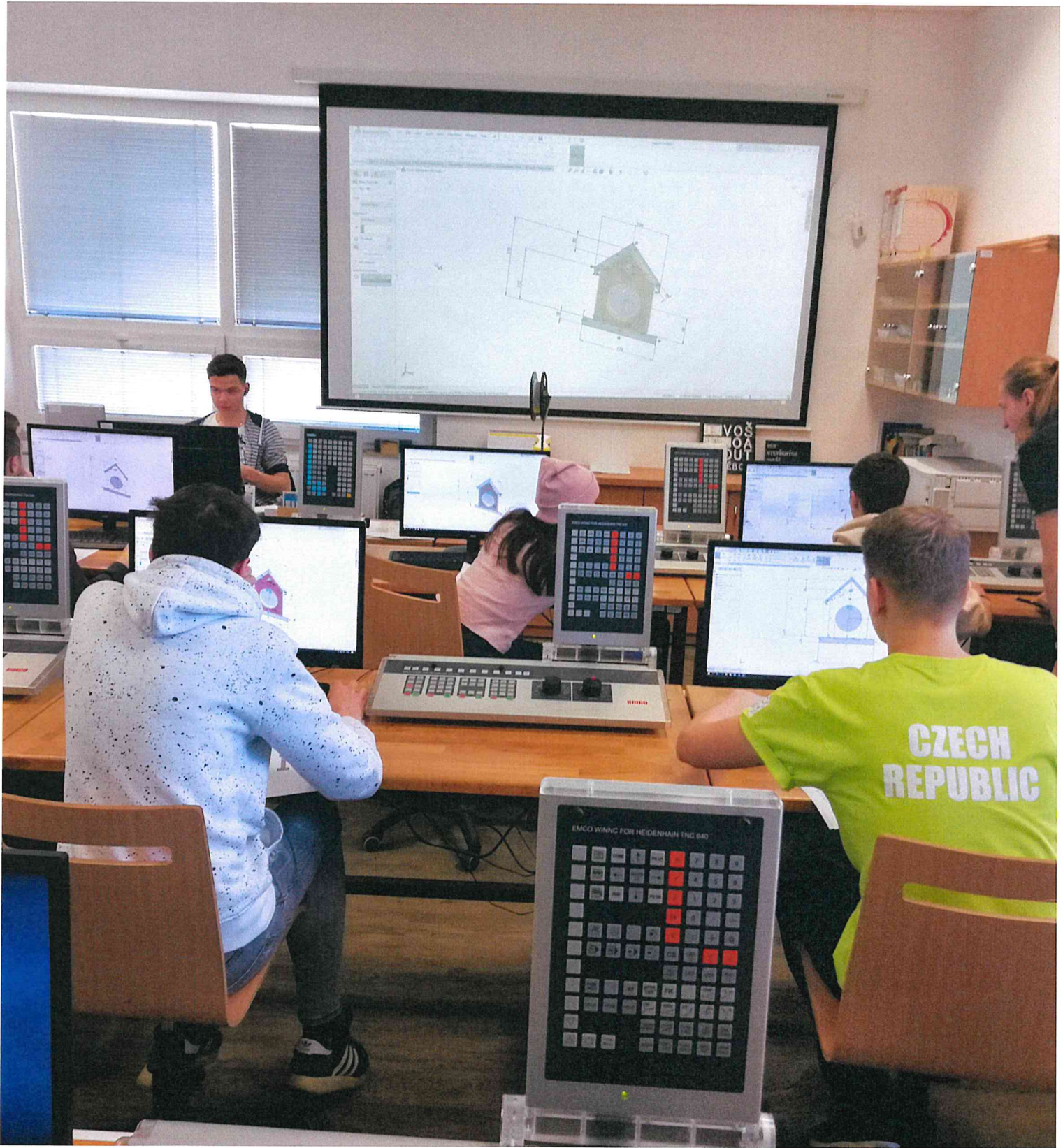





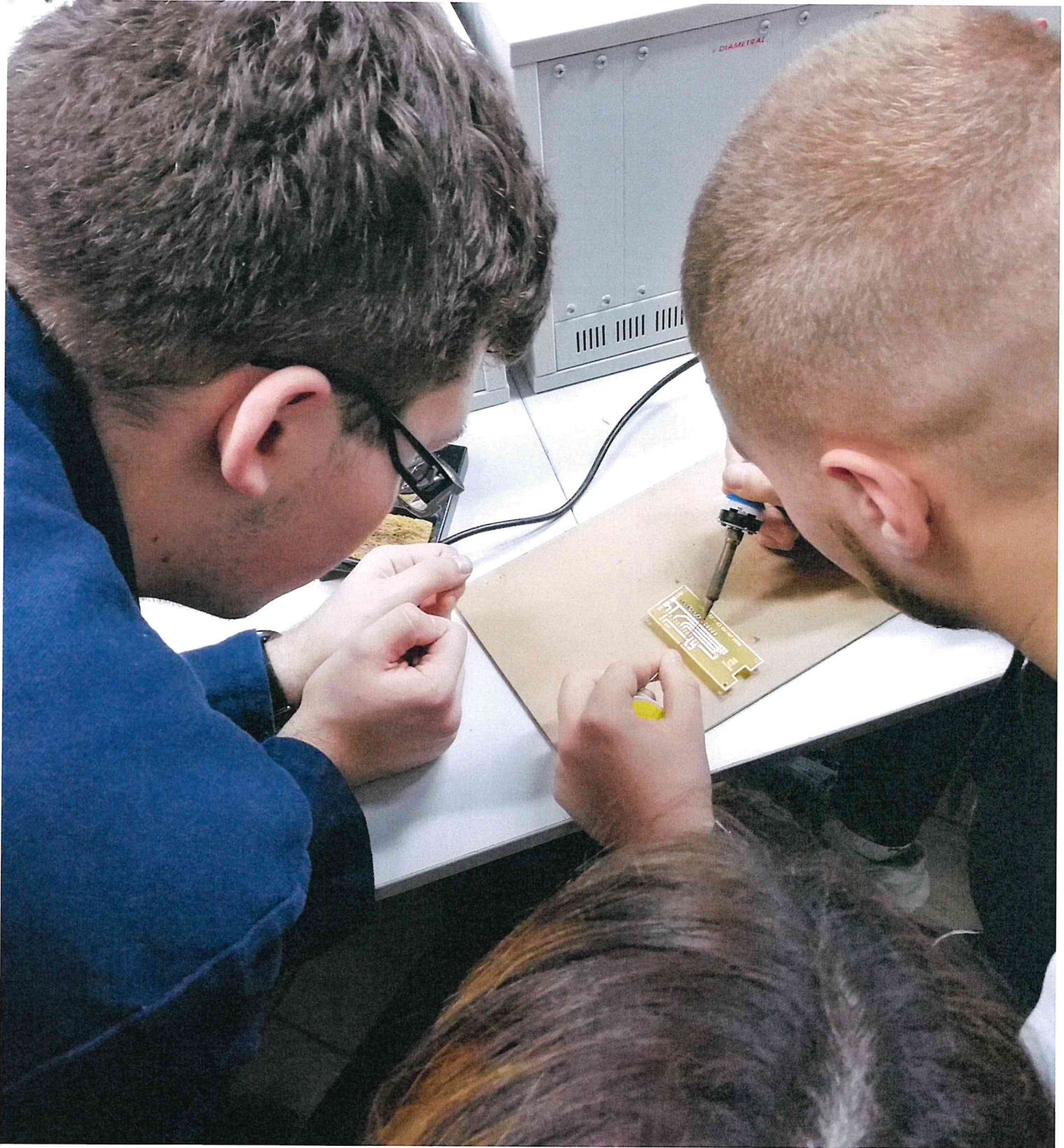

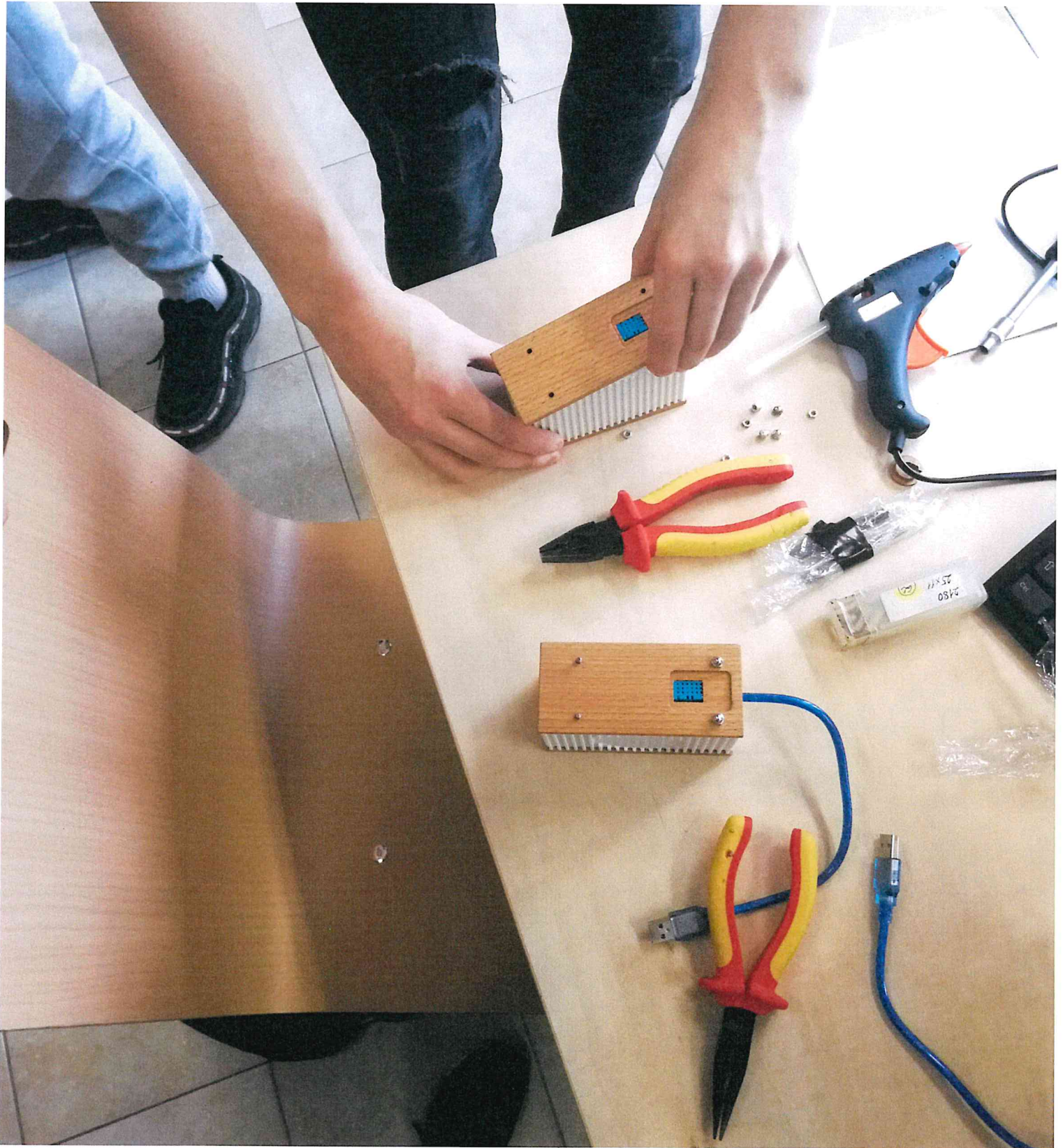

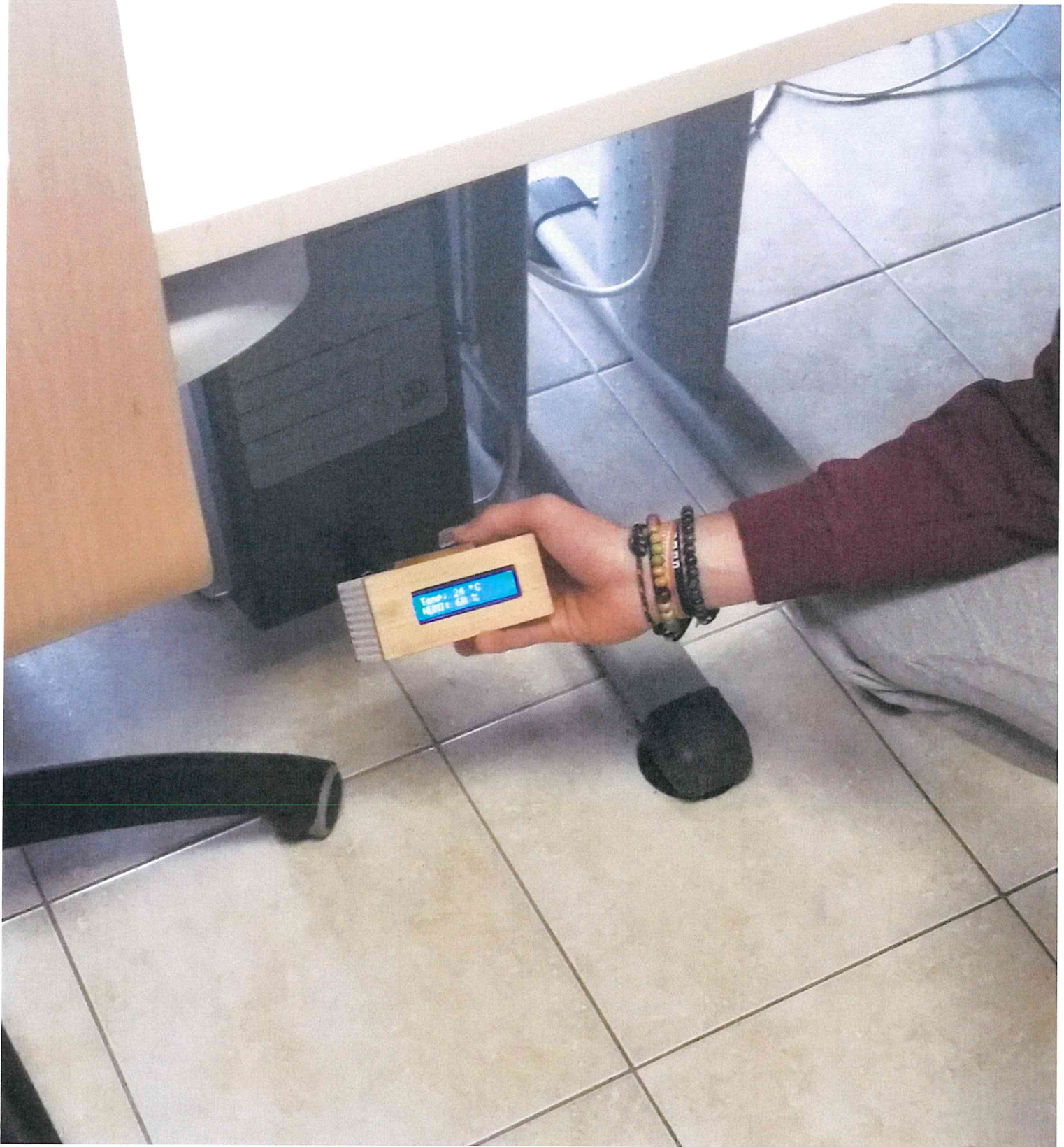



Erasmus+

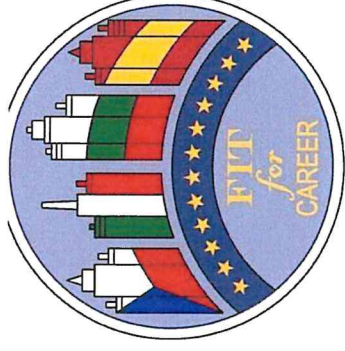

salesianos
SANTÍSIMA TRINIDAD

PROJECT “FIT FOR CAREER” ACTIVITY Nº1

Manufacture of squares with Flags. Welding and Painting

- 1.- CUT 4 PIECES DIMENSIONS 14X4 mm
- 2.- WELD 2 PIECES SQUARE AND 2 PIECES THE SAME
- 3.- MAKE ONE SQUARE
- 4.- MAKE ANOTHER EQUAL SQUARE
- 5.- MAKE HEXAHEDRON WITH MATERIAL 14X14 mm AND WELDING ELECTRODE OR MIG/MAG(FERROMAXX-MAG)
- 6.- FINAL DIMENSIONS 100X100X100 mm
- 7.- CUT 6 METAL FOIL 100X100mm



Erasmus+

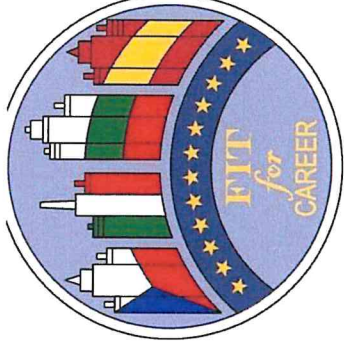

salesianos
SANTÍSIMA TRINIDAD

8.- ASSEMBLE WITH RIVETS DIMENSIONTS 4,8mm diameter , TWO RIVETS FOR FASE AND TWO DRILL 5 mm diameter FOR FASE.

8.- SAND AND CLEAN THE 6 METAL FACES OF THE HEXAHEDRO A LITTLE BEFORE ASSEMBLING WITH RIVETS

9.- PAINT IN THE PAINT BOOTH THE FLAGS OF THE DIFFERENT COUNTRIES, LEAVING EACH COLOR DRY 20 MINUTES

10.- ASSEMBLE WITH RIVETS DIMENSIONTS 4,8mm diameter , TWO RIVETS FOR FASE AND TWO DRILL 5 mm diameter FOR FASE, THIS ACTIVITY MUST MAKE IT SO THAT THE STUDENTS CAN FEED



Erasmus+

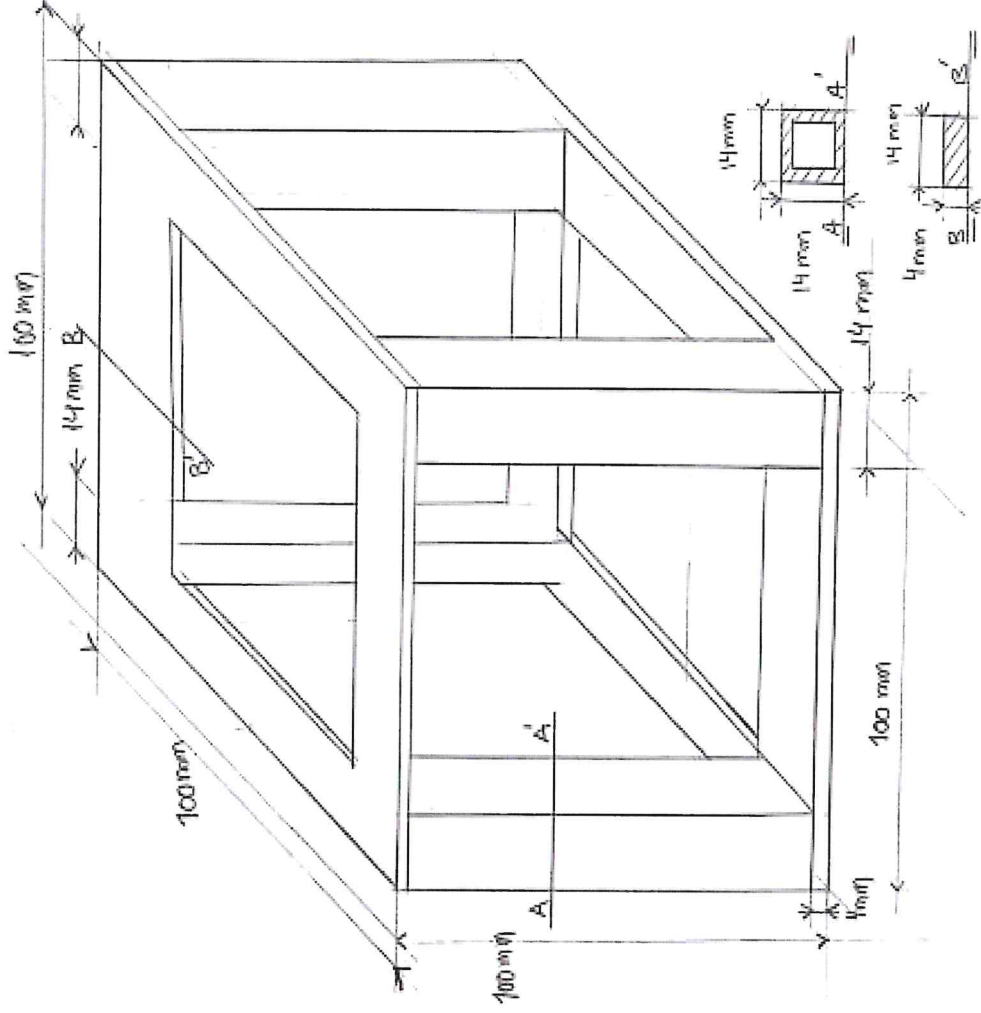







Erasmus+

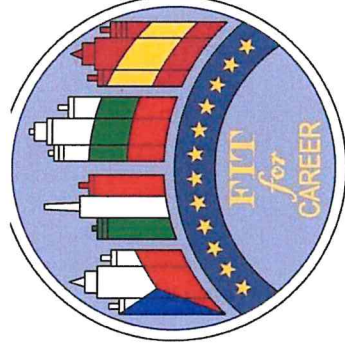

salesianos
SANTÍSIMA TRINIDAD

PROJECT “FIT FOR CAREER”

ACTIVITY Nº2

AUDIO DOOR ENTRY SYSTEM. KIT 4+N WIRES INSTALLATION

The tools and cable that you will use in this task are:

- Plain screwdriver
- Electrician scissors
- Connectors
- 12-wire cable

INTRODUCTION.-

- To make a call the visitor should press the push button corresponding to the wishes to contact. An acoustic tone will be heard confirming the call as the push is pressed. At this moment the call will be received at the telephone in the dwelling.
- To establish communication pick up the telephone handset.
- To open the door, press the door release push button at any moment.

STARTING RECOMMENDATIONS.-



Erasmus+

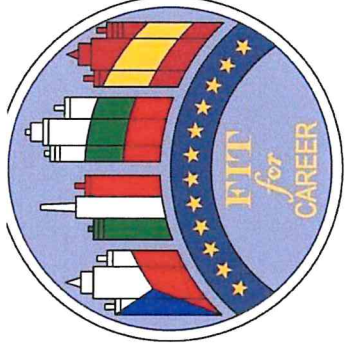

- Do not excessive force when tightening the transformer connector screws.
- Install the equipment without the power connected. Disconnect from power before any system modification. Check that the input voltage is lower than 230 a.c.
- Before to connect the system, ckeck the connections between door panel and telephones, and the transformer connection. Do always follow the enclosed information.

POWER SUPPLY INSTALLATION.-

The TF-104 transformer can be installed on a DIN guide simply pressing it. To disassemble the transformer from the DIN guide, use a plain screwdriver to lever the flange as shown on the picture.

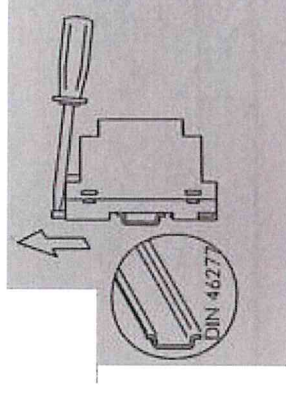

LOCK RELEASE INSTALLATION.-



Erasmus+

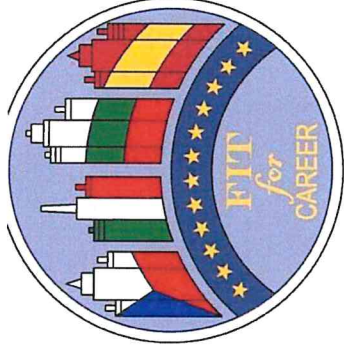

The lock release will be installed on the board as shown on the picture.

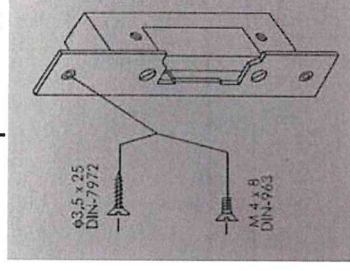

INSTALLATION DIAGRAM.-



salesianos
SANTÍSIMA TRINIDAD



Erasmus+



salesianos
SANTÍSIMA TRINIDAD

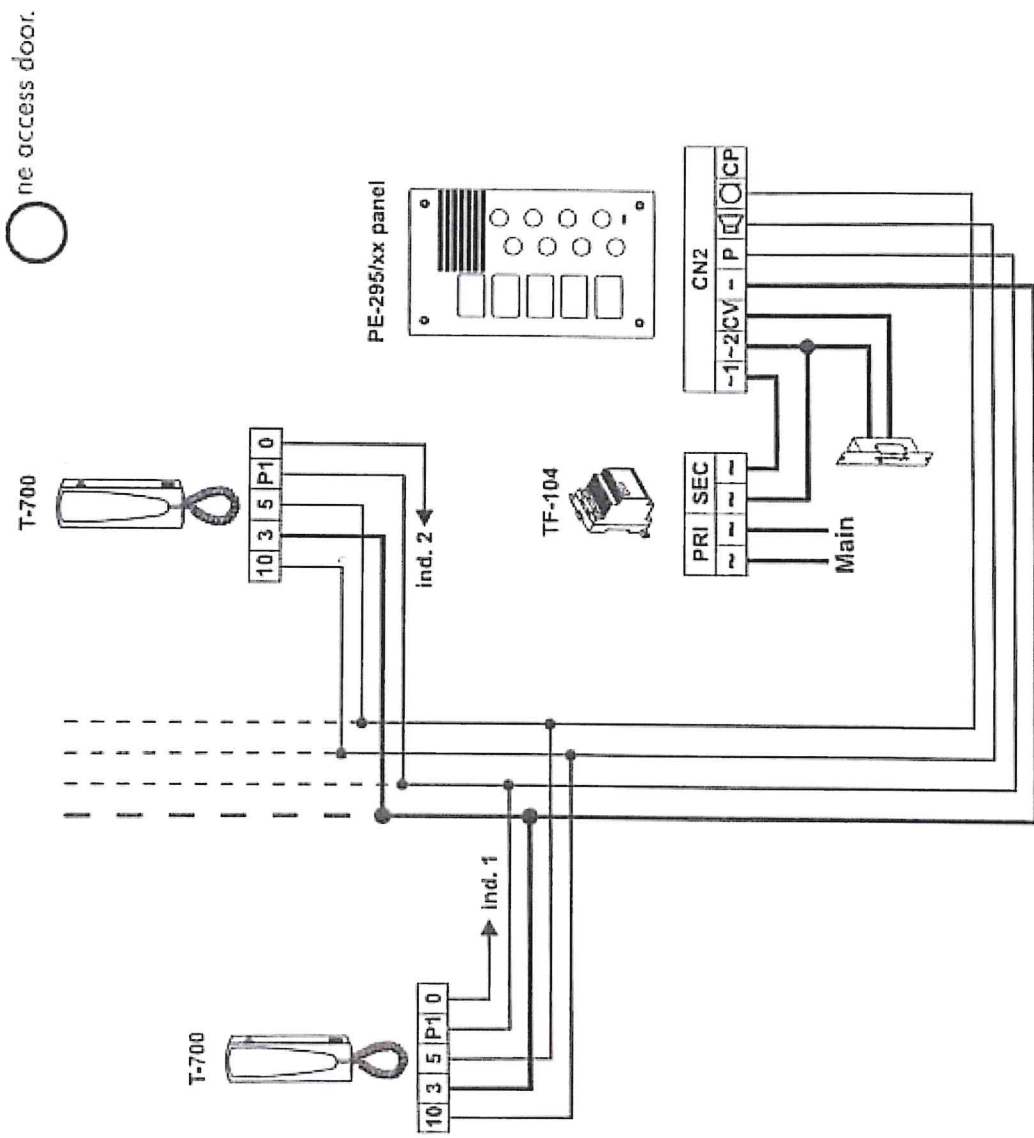



Erasmus+



salesianos
SANTÍSIMA TRINIDAD

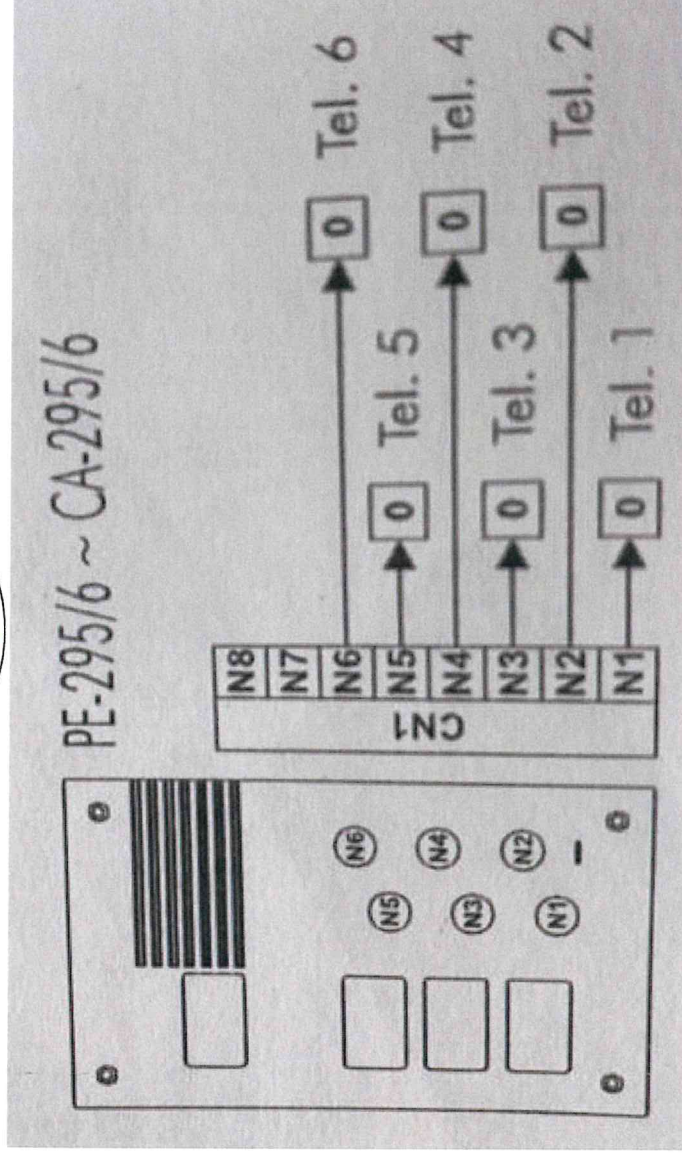

IMPORTANT NOTICE: the enclosed pictures draw the correspondence between each push button and its corresponding terminal on the CN1 connector. Terminals without arrow are not connected.



Erasmus+

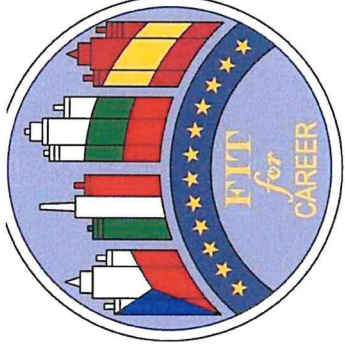

salesianos
SANTÍSIMA TRINIDAD

EXTERNAL LOCK RELEASE ACTIVATION.-

The lock release can be activated at any moment by using an external push button, that must be connected between “-” y “P” terminals of the main module.

This function will allow us to exit from the building being not necessary the use of a key.

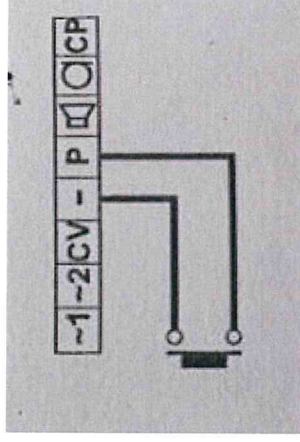

TROUBLESHOOTINGS HINTS.-

- No telephones receive the call or acknowledgement call signal is not reproduced.
 - Check that the call wires are connected to a valid terminals. In case of door panels with push button modules, check the “CP” terminal connectio to the main module.



Erasmus+

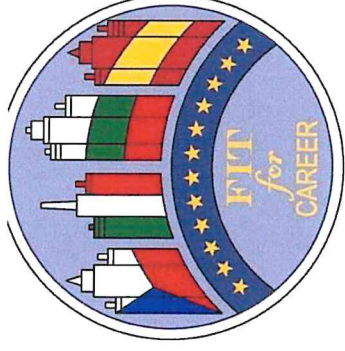

- Nothing operates.
 - Check the output transformer voltage between SEC terminal: it should have 12 to 17 Va.c. If not, disconnect the transformer from the installation and measure again. If it's correct now, it mean there is a short - circuit in the installation: disconnect the transformer from mains and check the installation.





